

## 2951.0200

Highline Custom corner incl. drain | 2951

The set consists of a Custom corner drain unit, Custom corner panel, spacers and glue.

Fits wall tiles in wall thickness 6-20 mm.

The recesses of the drain unit ensure correct positioning of the panel.

The glue provides optimum adhesion between panel and tile.



### Specifications

<b>ITEM NUMBER</b> 2951.0200	<b>GTIN NUMBER</b> 5707692012858	<b>WEIGHT INCLUDING PACKAGING</b> 1100 g
<b>WEIGHT EXCLUDING PACKAGING</b> 900 g	<b>MATERIAL</b> 1,5 mm stainless steel (AISI 304)	<b>USAGE</b> Corner drain
<b>SURFACE</b> Pickled	<b>MEMBRANE</b> Liquid or sheet membrane	<b>FLOOR CONSTRUCTION</b> All
<b>FLOORING</b> Tiles	<b>MOUNTING</b> 6 mm plugs 6 mm screws. Torx 20	<b>INSTALLATION LENGTH (L)</b> 377 x 267 mm

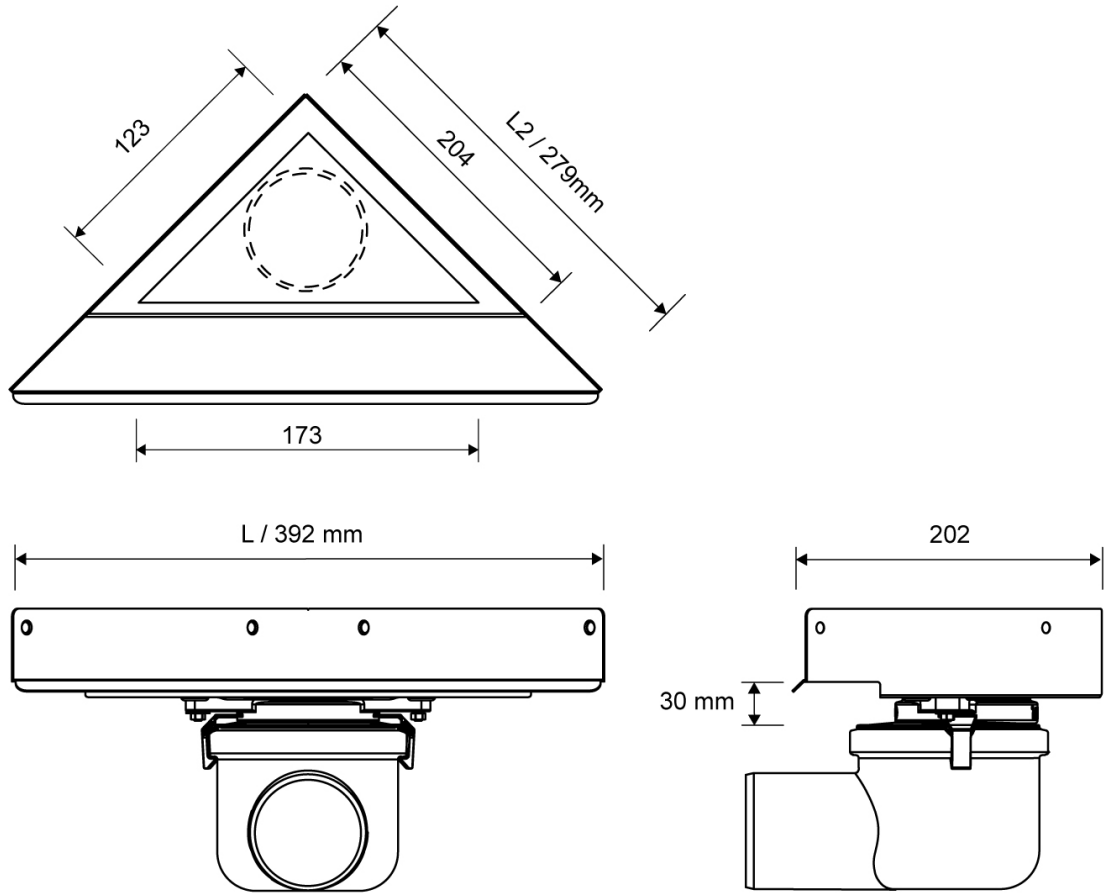

**2951.0200**

Products