

MCAC1-AP

Mandos

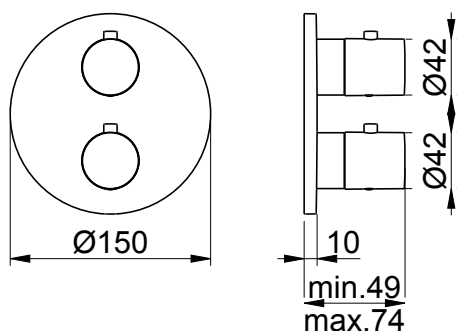

DESCRIPCIÓN

Mando termostático de 1 vía con embellecedor circular. Esta parte externa es compatible con el cuerpo empotrado **MC-UP**. Fabricado en acero inoxidable AISI 316 o latón.

DATOS TÉCNICOS

- Cierre de seguridad en: 38°
- Temperatura mínima de trabajo: 3°C
- Mínimo recomendado: 15°C
- Temperatura máxima de trabajo: 70°C
- Temperatura máxima recomendada: 65°C
- Diferencial térmico recomendado: 50°C
- Sistema de seguridad con parada de flujo en caso de falta - de una de las dos aguas.
- Rango de presión min/max. 0,5 - 5 bar (en caso de que la presión del agua sea superior a 5 bar se recomienda instalar reductores de presión).
- Presión recomendada: 3 bar.

ACABADOS DISPONIBLES

Acero inoxidable AISI 316

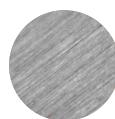

Acero inox.
cepillado



Gunmetal



Cobre
cepillado



Oro
cepillado

Latón



Blanco
mate

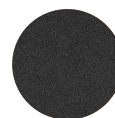

Negro
mate



Oro
brillante

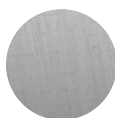

Níquel
cepillado



Cromo

CAUDAL (L/min)

bar	Mix 1 way
	Exit 1/2/3
0,5	10,7
1	15,3
2	21,8
3	26,8
4	31
5	34,8

MCAC1-AP

Mixers

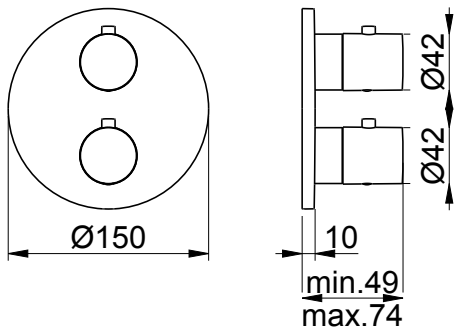

DESCRIPTION

1-way thermostatic control with circular trim.
Compatible with the MC-UP built-in body.
Made of Stainless Steel AISI 316 or brass.

TECHNICAL DATA

- Safety lock at: 38°
- Min. Working temperature: 3°C
- Min. recommended: 15°C
- Max. Working temperature: 70°C
- Max. recommended: 65°C
- Recommended thermal differential 50°C
- Safety system with flow stop in case of lack of one of the two waters.
- Pressure range min / max. 0.5 - 5 bar (in case that the water pressure is higher than 5 bar it is recommended to install pressure reducers).
- Recommended pressure: 3 bar.

FINISHES AVAILABLE

Stainless steel AISI 316

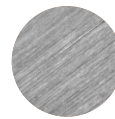

Brushed stainless steel



Gunmetal



Brushed copper



Brushed gold

Brass



Matt white



Matt black



Polished gold

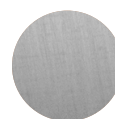

Brushed nickel



Chrome

FLOW RATE (L/min)

bar	Mix 1 way
	Exit 1/2/3
0,5	10,7
1	15,3
2	21,8
3	26,8
4	31
5	34,8